

# **OPERATING MANUAL**

**Point Level Transmitter**

**HK-7ELP**

Gamma Instrument Services  
90 Clairton Blvd.  
Suite 13  
Pittsburgh, PA 15236  
Tel: (412) 653-7717  
Fax: (412) 291-1245  
E-mail: HKInstrumentsBG@aol.com

## INDEX

	<b>Page</b>
I. Quick Calibration Procedures	
II.. System Description	5
III User Interface	5
• 1 Keypad	5
• 2 Menus	6
• 3 Entering Numbers	8
• 4 Entering Numbers in Screens that contain two (2) Variables	8
IV How to make it work, Using System software	8
• A General Menu	8
• 1 Locking the Keypad	8
• 2 Unlocking the Keypad	9
• 3 Changing the Language for your Evaluation Unit	9
• 4 Changing the Date and Time	9
• 5 Selecting Units of Measure	10
• B Meas. Par. Menu	10
• 1 Setting the system time constant (signal averaging)	10
• 2 Setting the 4 mA of the system current output	10
• 3 Setting the 20 mA of the system current output	11
• C Operate Menu	11
• 1 Getting live readings in the display	11
• 2 Getting Product Temperature readings in display	12
V. CALIBRATION	13
• D Calibr. Menu (Calibration)	13
• 1. Single Point Calibration	13
• 2 Entering the absorption coefficient for Single Point Calibration	13
• E Service Menu	14
• 1 Selecting an Isotope	14
• 2. Entering a test countrate	15
• 3 Selecting 0-20 mA or 4-20 mA for output	15
• 4 Selecting 0-20 mA or 4-20 mA for input	15
• 5 Entering a test current	15

## APPENDIX

HK-7EL Wiring Diagram

HK-7EL Dimensional Drawing

HK-72B Detector Drawing

## I Quick Calibration Procedure

- A. It is required that count rates measured by the Scintillation Detector for different levels be read into the Level Transmitter. This is done in the Calibr. Menu. There are 2 pairs of data in the Calibr. Menu. Each calibration pair represents the Level and Countrate of the product at different filling points.
- B. You must also set up High/Low alarm trip points and the Hysteresis around those set points.

**1. Accessing the Calibration Menu**

At the Main Screen (display 1) Press <SK3> Until Display 4 Appears. Select Calibr. Menu, Press <SK1> Display 6a will appear.

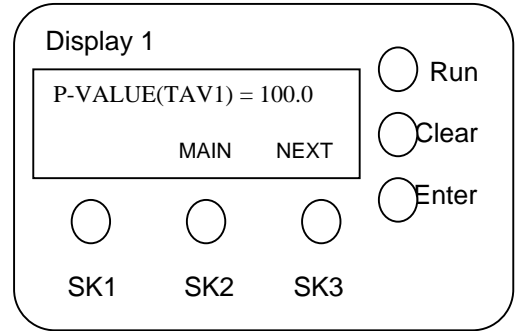

**2. Entering Calibration Points**

see screen 6a. There are two (2) values in this screen. EMPTY: L= 0.0 and I= 125. The L represents the Filling level. The I= 125 represents the countrate, which is measured by the Scintillation Detector when the vessel is empty.

To start live countrate reading, Press Enter. The cursor will now be positioned under the countrate. Press Run, the countrate will begin to change and stabilize after approximately 1 minute. Press Run to stop measurement. Press Enter to lock countrate into the register and proceed to the next screen.

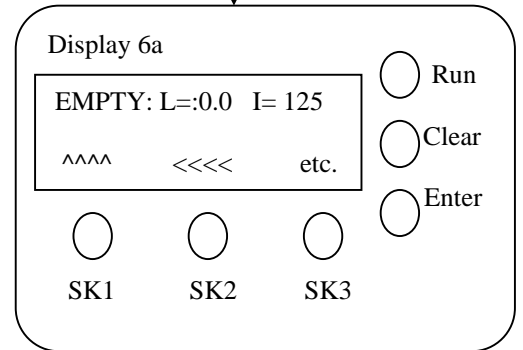
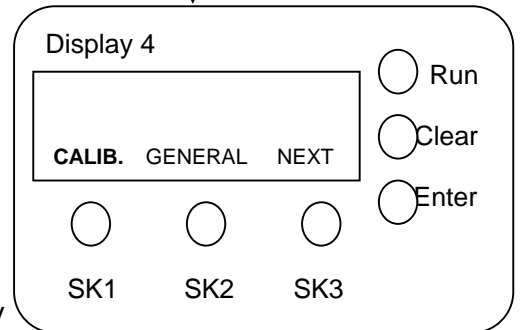

Display 6b shows the second data pair. 30 can be manually Entered For this value. Press Enter to place the cursor under he countrate. Use SK2 to move the cursor and SK1 to change values. Press Enter Unit is now calibrated and you will return to the main screen

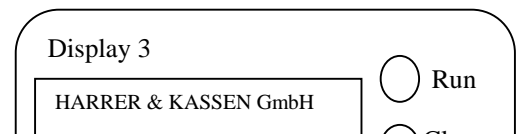
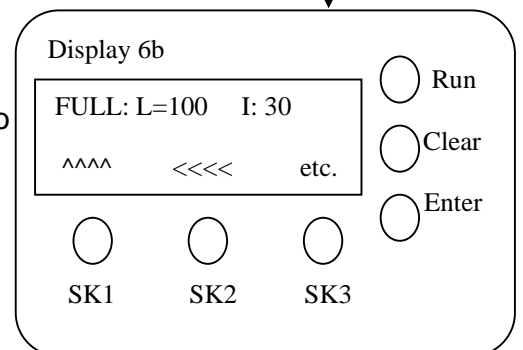

### 3. Setting Alarm Points

At Main Screen (Display 1) Press <SK3> Until Display 3 appears  
Press MEAS. PAR. at <SK2>

Press NEXT <SK3> until Screen 6c Appears. You will set the Low Alarm at this screen. Use <SK2> to position the cursor, use <SK1> To change values. ALARM VALUE SHOULD BE SET AT 50.  
Press Enter to lock value in the register or NEXT to proceed to the next Screen (Screen 6d)

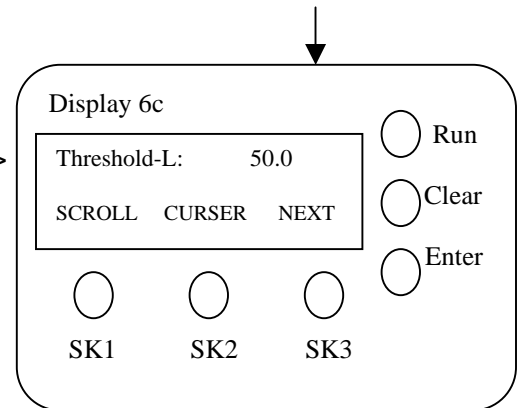

You will set the High Alarm at Screen 6c. Use <SK2> to position Cursor and <SK1> to change values ALARM VALUE SHOULD BE SET AT 50. Press Enter to lock value in the register or NEXT to proceed to the next Screen (Screen 6e).

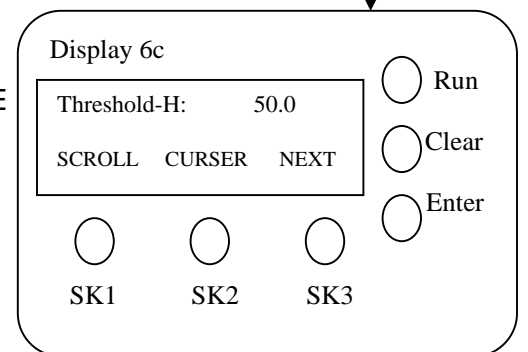

You will set around the alarm set points at this screen. Use <SK2> To position the cursor and <SK1> to change the values. 5 IS A Good Starting Point Press Enter to lock the value into the register or Next to change screens. Press RUN to return to the main screen and begin the measurement

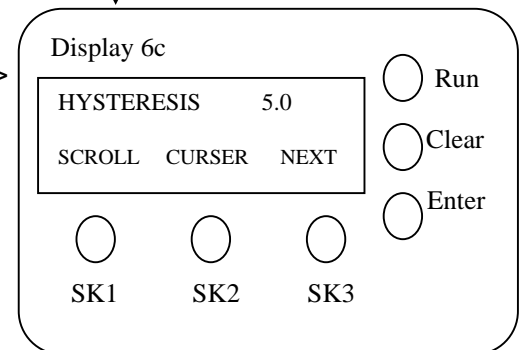

## I. System Description

- A. The Level Transmitter is designed to make a non-contacting measurement of the Level in a Vessel, Chute or pipe.

## II. User Interface

The parameters that set up the Level Transmitter and allow the user to perform the required operations are accessed through the keypad located on the front panel of the Transmitter (Figure 1). There are six (6) buttons, which allow the user to interface with the menu driven software that runs the Density Transmitter.

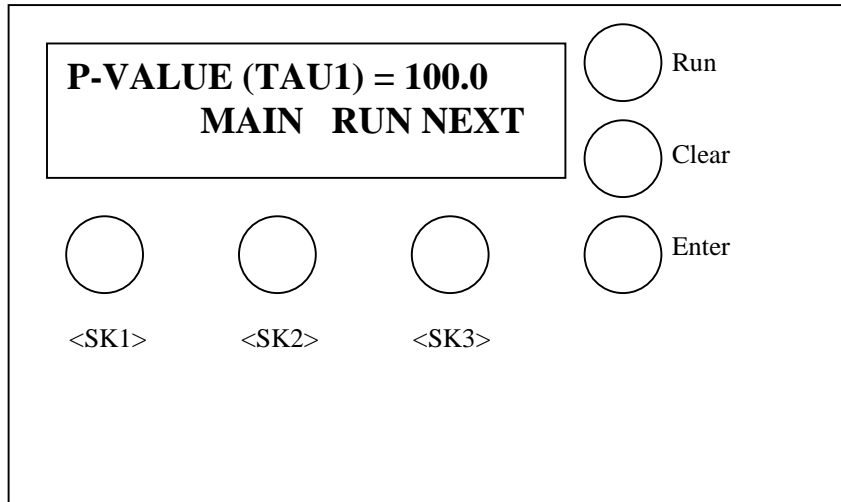

**Figure 1**

### 1. Keypad

#### a) Description of keypad buttons

- |         |   |
|---------|---|
| <SK1>   | <ul style="list-style-type: none"> <li>♦ Selection of menus and sub-menus</li> <li>♦ Entering of numbers, when necessary</li> <li>♦ Viewing of options within a sub-menu</li> </ul> |
| <SK2>   | <ul style="list-style-type: none"> <li>♦ Selection of menus and sub-menus</li> <li>♦ Moving of cursor when entering numbers</li> </ul>  |
| <SK3.>  | <ul style="list-style-type: none"> <li>♦ Use this button to move from one menu position to the next</li> </ul>  |
| <Enter> | <ul style="list-style-type: none"> <li>♦ This button is pressed to confirm an input or change</li> </ul>  |
| <Clear> | <ul style="list-style-type: none"> <li>♦ Press to clear display and return to last known value</li> </ul>   |
| <Run>   | <ul style="list-style-type: none"> <li>♦ Starts and stops the measurement</li> </ul>  |

### 2. Menus

The Level Transmitter uses the following menus to configure the system:

- ◆ General
- ◆ Meas. par
- ◆ Measure
- ◆ Calibr.
- ◆ Service

<b>Menu Name</b>	<b>Menu Description</b>
<i>General</i>	<p>General system parameters are located in this menu:</p> <ol style="list-style-type: none"> <li>1) Locking and unlocking the keypad</li> <li>2) Selection of language</li> <li>3) Program version</li> <li>4) Date</li> </ol>
<i>Meas. Par.</i>	<p>Specific system parameters are located in this menu:</p> <ol style="list-style-type: none"> <li>1) Time constant for signal averaging for 1<sup>st</sup> current output</li> <li>2) Current output values for 1<sup>st</sup> current output scaling</li> <li>3) Time constant for signal averaging for 2<sup>nd</sup> current output</li> <li>4) Current output values for 2<sup>nd</sup> current output scaling</li> <li>5) Min and Max Threshold Values with Hysteresis setting</li> </ol>
<i>Measure</i>	<p>Measured values are displayed in this menu. No inputs allowed:</p> <ol style="list-style-type: none"> <li>1) Live display of measurement</li> <li>2) Live display of Countrates</li> </ol>
<i>Calibr.</i>	<p>Calibration is performed in this menu:</p> <ol style="list-style-type: none"> <li>1) Calibration data points are located here (Optional)</li> </ol>
<i>Service</i>	<ol style="list-style-type: none"> <li>1) Select Isotope for Decay Compensation</li> <li>2) Test rate can be selected here to test unit.</li> <li>3) Starting point of measurement entered here</li> <li>4) Current output selection of 0-20 mA or 4-20 mA</li> <li>5) Current input selection of 0-20 mA or 4-20 mA</li> <li>6) Test current output selected here</li> <li>7) The output of the current during the hold condition is set here</li> </ol>

### 3. Entering Numbers

Entering numbers is quite easy. Three buttons are used to enter numbers - <SK1>, <SK2>, and Enter.

<SK1> is used to increase the number directly over the Cursor.

<SK2> moves the Cursor to the left.

Enter button confirms entry.

Let's enter a new number in the display for date and time.

Current value = 04.09.98 16:27

New value = 04.09.99 16:29:

Step 1. Looking at display 1, increase the number over the Cursor to the number 9. It is now 7.

Press the <SK1> button until the number 9 is seen over the Cursor (display 1a). Press Enter.

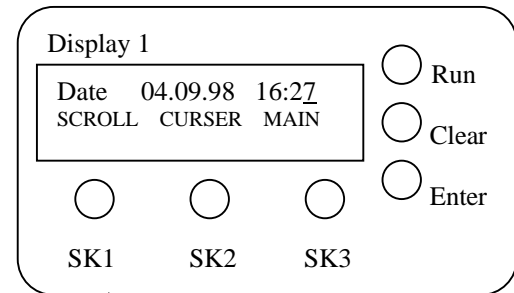

Step 2. Change the year to 99. Press <SK2> until the Cursor is positioned under the 1 (display 1b).

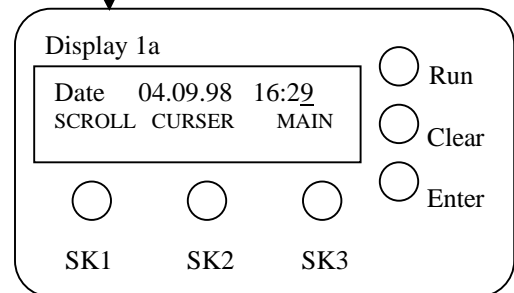

Step 3. Press the <SK1> button until the number 9 is seen over the Cursor (display 1c).

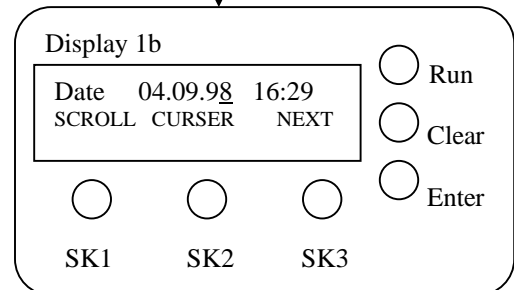

Step 4. Press Enter button and change the date from 04.09.98 16:27 to 04.09.99 16:29.

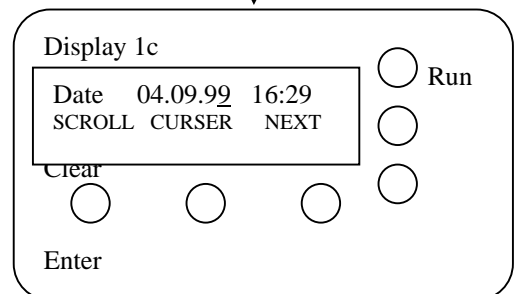

#### 4) Entering numbers in Screens that contain two (2) Variables.

**Note: There are certain screens, which contain two (2) variables, which must be entered. These screens are:**

1. The Data Pairs in the Calibration Menus. Each screen contains both the % of filling level and the Scintillation Detector Countrate.

### III. How to make it work, Using System software

#### A) General Menu

**1. Locking the keypad** – when it is necessary to protect the data in your evaluation unit from unauthorized access, it is possible to enter a passnumber to lock out keypad access.

**Note: Make sure the system is in the RUN mode before locking the keypad.**

Step 1. Press the <SK3> button until you see the word General displayed.

Step 2. Press the <SK> button, which selects the General Menu. The first display in the General menu is display 2a.

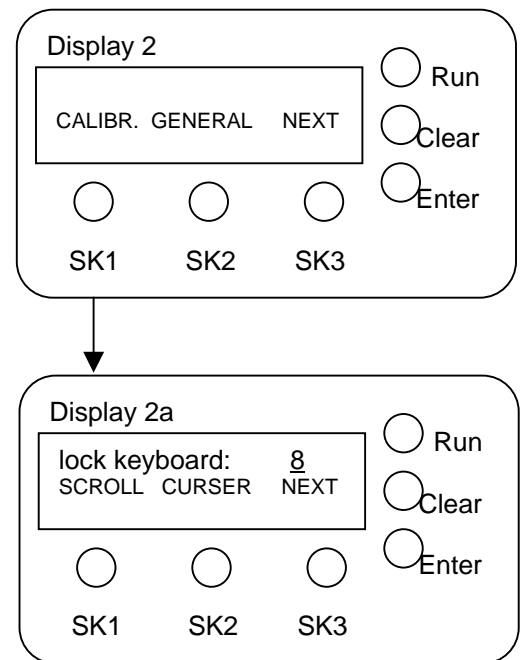

Step 3. Press <SK1> to place a number over the Cursor. 8 will be entered here.

Step 4. Press <SK2> to move the Cursor. Repeat Step 3.

Step 5. After you have placed your passnumber in the display press the Enter button. This number has become your password. The keypad is now locked and you must re-enter this passnumber to unlock it.

**2) Unlocking the keypad** – if you have entered a number to lock the keypad, you must re-enter that number

according to the following steps to unlock the keypad and gain access:

- Step 1. Select the General Menu.
- Step 2. Press <SK3> button until display 2b is shown.
- Step 3. Press <SK1> button to place a number over the Cursor.
- Step 4. Press <SK2> to re-position the Cursor.
- Step 5. Repeat until you see your passnumber in the display.
- Step 6. Press the Enter button to unlock keypad.

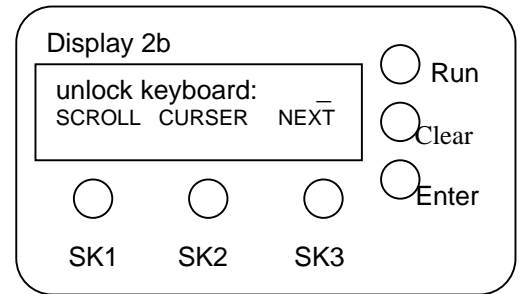

### 3) Changing the language of your Evaluation Unit

- Step 1. Select the General Menu.
- Step 2. Display 2a should be in the display .
- Step 3. Press <SK3> button until display 2c is shown.
- Step 4. Press <SK1> button until language of choice is shown.
- Step 5. Press the Enter button to select language in display.

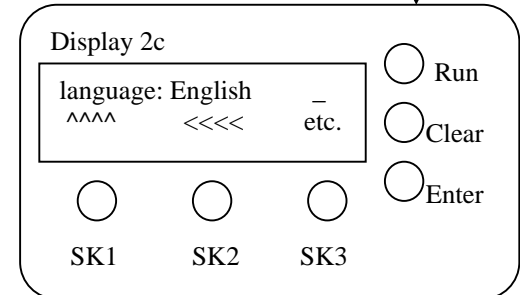

### 4) Changing the time and date in the Evaluation Unit.

Format is European - day:month:year hour:minute

- Step 1. Select the General Menu.
- Step 2. Display 2a should be in display .
- Step 3. Press <SK3> button until display 2d is shown.
- Step 4. Press <SK1> button to change the value of the number directly over the Cursor.
- Step 5. Press <SK2> to re-position the Cursor.
- Step 6. When the time and date in the display is correct, press the Enter button for the Evaluation Unit to accept value.

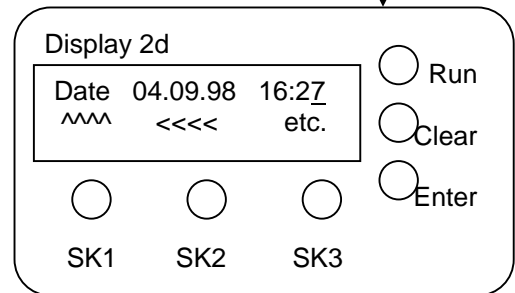

## B. Meas. Par. Menu

### 1) Setting the system time constant.

The value of the time constant will depend on the following factors:

- 1) The rate at which the level may change.
- 2) The requirements of the control loop.

A good starting value be 20.0 sec. This can be reduced or increased depending on the performance of the instrument. Too low is not good (1 sec) and too high is not good (100 sec).

- Step 1. Select the Meas.Par. Menu, Press <SK2> display 1.
- Step 2. Display 3a should be shown.
- Step 3. Press <SK1> button to change the number above the Cursor.
- Step 4. Press <SK2> button to re-position the Cursor.
- Step 5. Press Enter button when the display shows the time constant you wish to use.

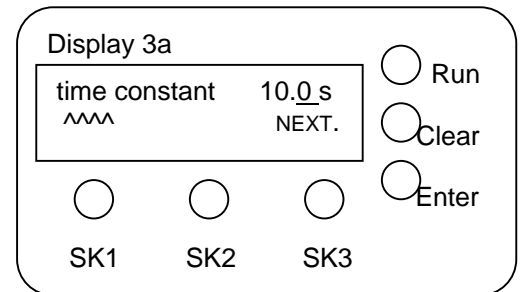

### 2) Setting the 4 mA of the system current output.

- Step 1. Select the Meas. Par. Menu.
- Step 2. Display 3a should be shown.
- Step 3. Press <SK3> button until display 3b is shown.
- Step 4. Press <SK1> button to change the number over the Cursor.
- Step 5. Press <SK2> button to move the Cursor.
- Step 6. Press Enter button when the desired 4-mA value is in the display. In this case, the value representing 4 mA will be 0.0 g/cm<sup>3</sup>.

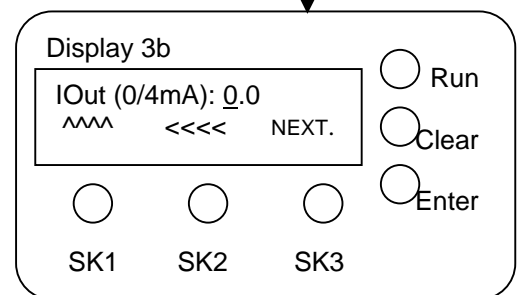

### 3) Setting the 20 mA of the system current output.

- Step 1. Select Meas.Par. Menu.
- Step 2. Display 3a should be shown.
- Step 3. Press <SK3> button until display 3c is shown.
- Step 4. Press <SK1> button to increase the number over the Cursor
- Step 5. Press <SK2> button to move the Cursor.
- Step 6. Press Enter button when the desired 20 mA value is in the display. In this case the value representing 20 mA is 1.0 g/cm<sup>3</sup>.

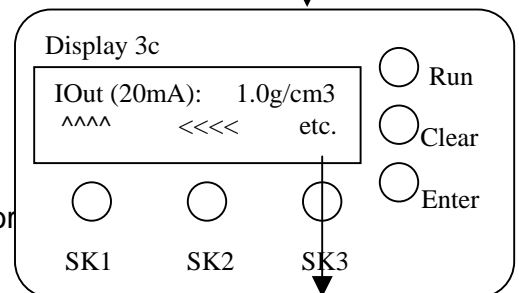

## C. Operate Menu

### 1) Getting the live reading of the units of measure in the display.

Step 1. Select the Measure Menu.

Step 2. Display 4a should be shown, live readings should be in display. Display 4a is not in the Run mode.

Step 3. Press Run Button to place system in measurement mode.

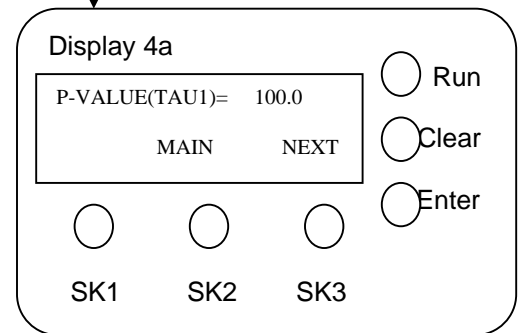
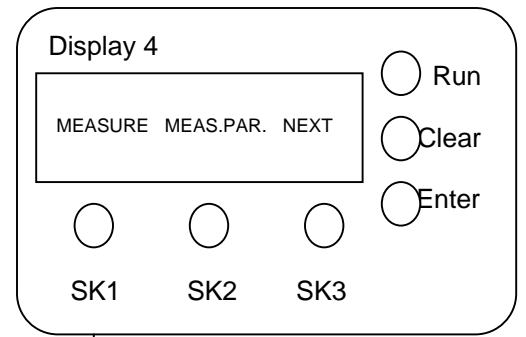
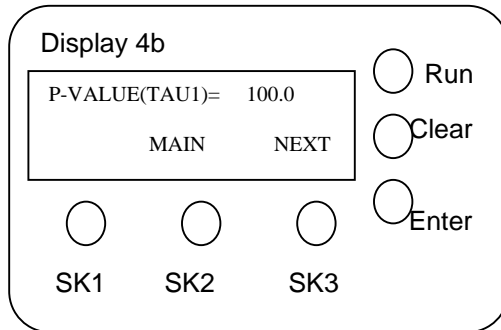

## IV. Calibration

- B. It is required that count rates measured by the Scintillation Detector for different levels be read into the Level Transmitter. This is done in the Calibr. Menu. The level should be measured at 2 points.
- B. There are 2 pairs of data in the Calibr. Menu. Each calibration pair represents the Level and Countrate of the product at different filling points.

**D. Calibr. Menu**

**1. Entering Calibration Points**

Select Calibr. Menu, Press <SK1> Display 4 see screen 6a. There are two (2) values in this screen. EMPTY L: 0.0 and I: 998. The L represents the Filling level of the product for sample #1. The I: 998 represents the countrate, which is measured by the Scintillation Detector when the vessel had a filling level of 0.00%

Display 6b shows the second data pair. The density for point one was 1.000 g/cc and the density for point 2 is 1.100 g/cc. The countrate for point 1 was 27000 and for point 2 is 18500.

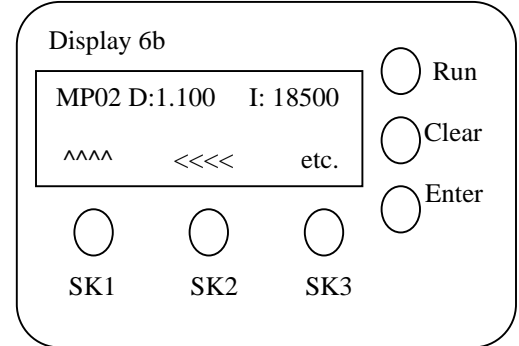
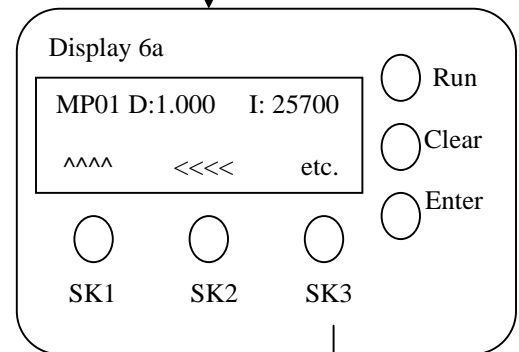
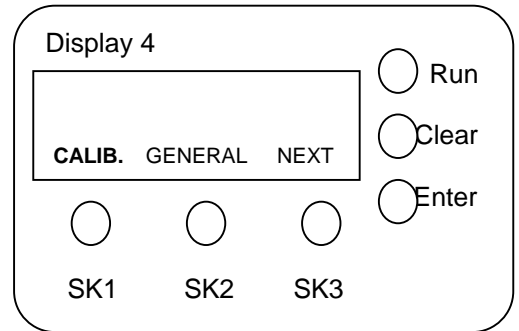

**E. Service Menu**

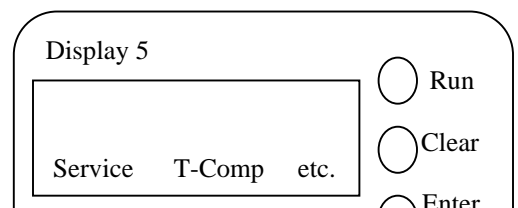

1. Select Isotope. You have the choice of either Cs-137 or Co-60 for an Isotope. The default is Cs-137.

- a. To change the Isotope, Select The Service Menu, Display 5, and you will see 5a.
- b. When in screen 5a, you can change the Isotope by pressing the SK1 button. By pressing the SK1 button, the Isotope in the screen will switch between Cs-137 and Co-60. When you have the Isotope you want in the Screen, Press the enter button.

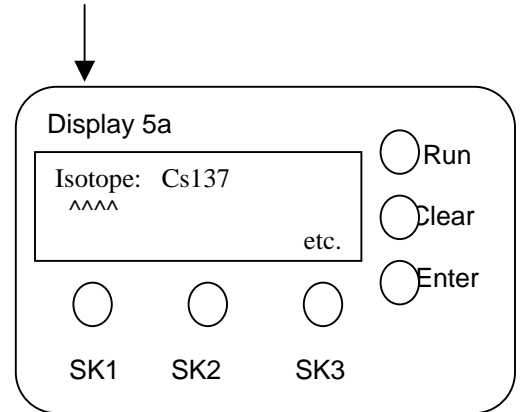

2. Testrate

You can test the output of the unit by entering a test rate in Display 5b.

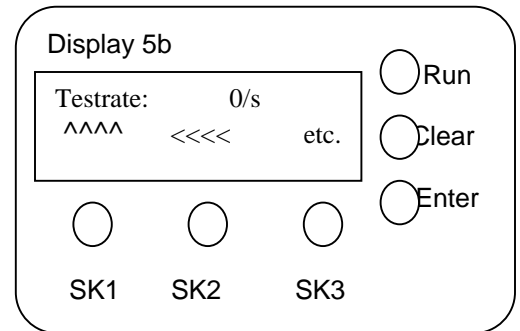

3. Selecting a 0-20 mA scale or a 4-20 mA scale for output

- Step 1. Select the Service Menu.
- Step 2. Display 5a should be shown.
- Step 3. Press <SK3> button until display 5c is shown.
- Step 4. Press <SK1> button to select 0-20 or 4-20 mA.
- Step 5. Press Enter button when desired value is in display.

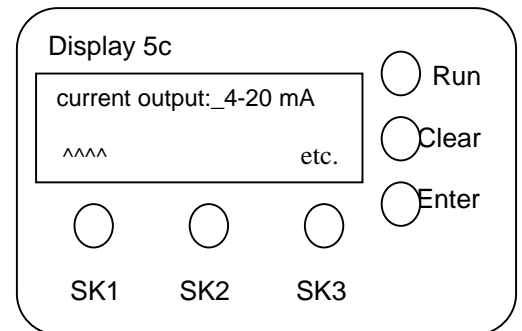

4. Selecting a 0-20 mA scale or a 4-20 mA scale for input

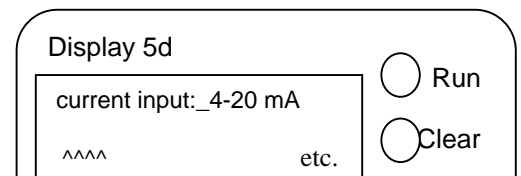

- Step 1. Select the Service Menu.
- Step 2. Display 5a should be shown.
- Step 3. Press <SK3> button until display 5d is shown.
- Step 4. Press <SK1> button to select 0-20 or 4-20 mA.
- Step 5. Press Enter button when desired value is in display.

### 5. Entering a test current (must not be in Run mode)

- Step 1. Select Service Menu.
- Step 2. Press scroll key until display 5e is shown.
- Step 5. Press scroll button to select the value of the test current. The system will output 4 mA when it looks like Display 5e, with 5 mA entered.

Input: 0 = test current off  
 1 = current output of 0 mA  
 2 = current output of 1 mA  
 21 = current output of 20 mA

- Step 6. Press Enter button when desired value is in display.

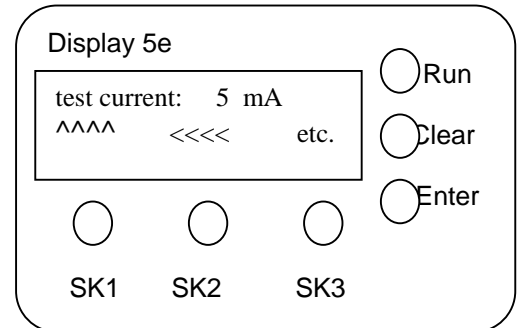

**NOTE: YOU MUST ENTER A VALUE THAT IS 1 NUMBER HIGER THAN THE CURRENT OUTPUT YOU WANT TO MEASURE.**

### 8. Selecting the value of the current output during a hold condition

- Step 1. Select the Service Menu.
- Step 2. Display 5a should be shown.
- Step 4. Press <SK3> button until display 5i is shown.
- Step 5. Press <SK1> button to select the value of the current loop during a hold condition. The value can be, hold last reading, hold 0 mA, hold 4 mA, or hold 20 mA.
- Step 6. Press Enter button when desired value is in display.

# Technical Data

## LEVEL Meter HK7-EL

Utilities:	AC 220/110 V 47-65 Hz approx 15VA
Repeatability:	+/- 0.1 %
Time constant:	0.1 – 999.9 s
Data storage:	non-volatile flash e-prom
Decay compensation:	automatic control via quartz clock
Display:	alphanumeric 2 X 24 characters LCD, dialogue with push buttons
Housing:	NEMA 4X, IP 65
Operating temperature:	-20 to 50 deg.C
Analog output:	x 2 isolated, 0/4 to 20 ma, maximum load 500 ohm

June 1, 2004

[Seitenanfang](#)

## QUICKON components

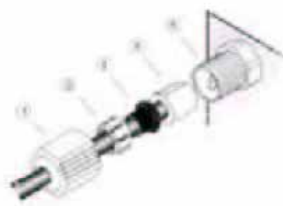

1. Union nut
2. Collar
3. Rubber seal
4. Splice ring
5. Contact carriers

[Seitenanfang](#)

## Assembly of the conductor with QUICKON

QUICKON - the new type of connection system makes the installation of e.g. sensors, actuators and other system components in automation technology not only faster but also simpler and less expensive. The assembly principle of QUICKON is extremely simple.

[Seitenanfang](#)

### 1. Preparation

- Remove approx. 15 mm of the cable sheath,
- Slide on the union nut, the cap and the rubber seal.

[Seitenanfang](#)

- Insert the core ends into the feed-through of the splice ring. To ensure correct assignment, these are numbered.
- Cut off the projecting core ends (the core ends may project from the splice ring by a maximum of 2 mm)



[Seitenanfang](#) 

### 3. Tightening

- Insert the prepared conductor into the contact carrier,
- Tighten the union nut. QUICKON automatically makes the contact and creates the strain relief when tightened. Special seals protect against dust and splashed water (IP65 / IP67).

[Seitenanfang](#) 

### Removing the conductor

- Opening screw connection
- Pull at the cables so that the cores come out of the terminal points.
- Surplus insulation must be removed before reconnection.

[Seitenanfang](#) 

### Reconnecting the conductor

- Cut off approx. 20 mm from the conductor end,
- Reassemble as described above.

[Seitenanfang](#) 

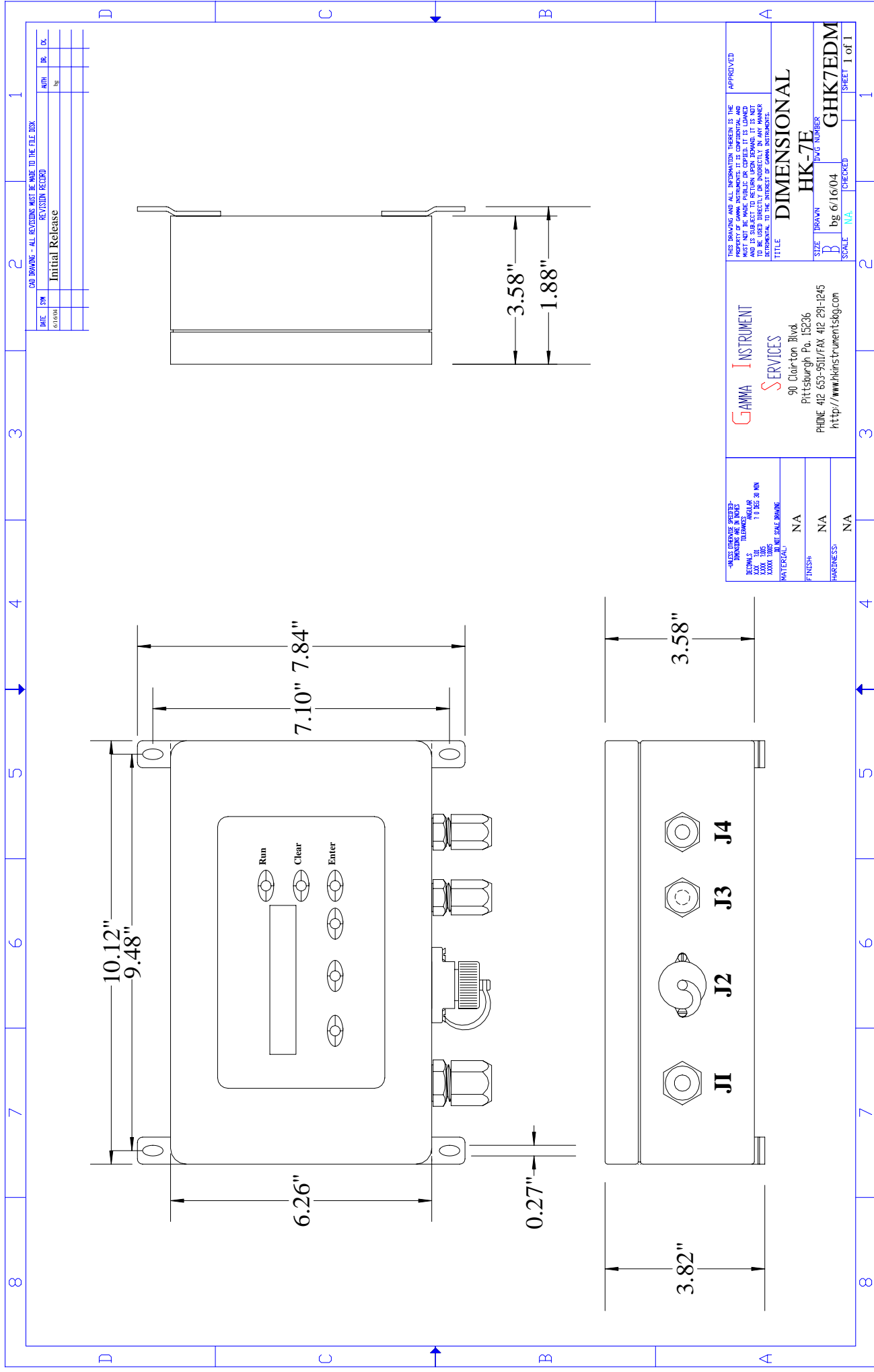

DATE: 1/20/04  
 BY: [Signature]

REVISION RECORD

REV	DATE	BY	DESCRIPTION
1			Initial Release

ALL DIMENSIONS - ALL REVISIONS MUST BE MADE TO THE FILE BOX

UNLESS OTHERWISE SPECIFIED:  
 DIMENSIONS ARE IN INCHES  
 DECIMALS TO THIRDS  
 FRACTIONS TO SIXTEENTHS  
 TOLERANCES UNLESS SPECIFIED:  
 XXX .005  
 XXXX .003  
 XXXXX .002

FINISH: NA  
 HARDNESS: NA

DATE: 1/20/04  
 BY: bg  
 CHECKED: [Signature]

APPROVED: [Signature]

TITLE: DIMENSIONAL  
 PART NUMBER: HK-7E  
 SCALE: 1/1

SIZE: B  
 DRAWN: bg  
 DATE: 6/16/04  
 CHECKED: [Signature]

PHYSICAL: NA  
 FINISH: NA  
 HARDNESS: NA

GAHWA INSTRUMENT SERVICES  
 90 Clairton Blvd.  
 Pittsburgh Pa. 15236  
 PHONE 412 633-9511/FAX 412 291-1245  
<http://www.hkinstrumentsag.com>

GHK7EDM  
 SHEET 1 of 1

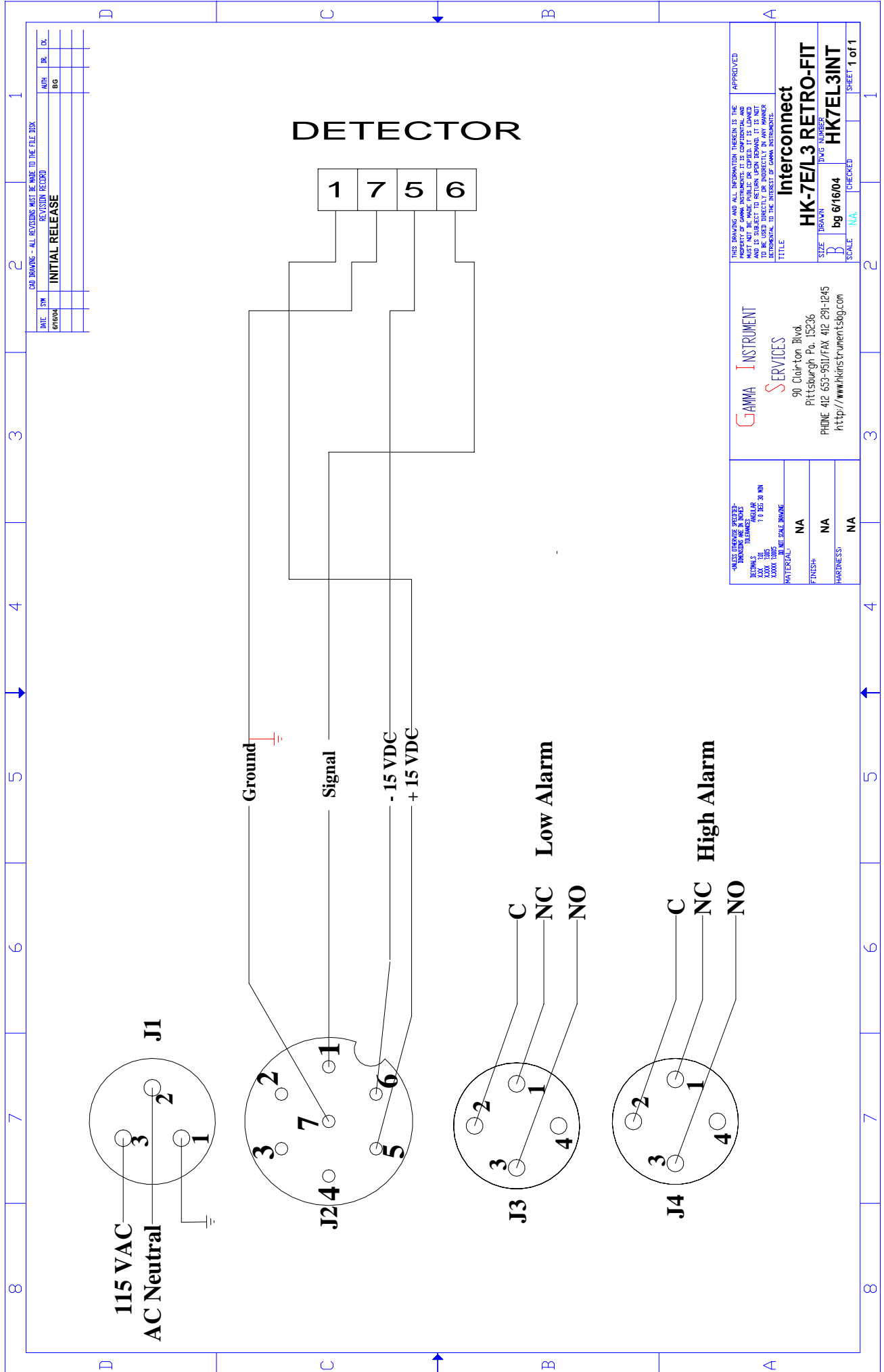

# DETECTOR

DATE: 1/28/04  
 INITIAL RELEASE  
 AUTH: BG  
 DR: DC

THIS DRAWING AND ALL INFORMATION THEREON IS THE PROPERTY OF GAMMA INSTRUMENTS. IT IS CONFIDENTIAL AND MUST NOT BE MADE PUBLIC OR COPIED. IT IS LOANED TO YOU FOR YOUR USE ONLY AND IS NOT TO BE USED DIRECTLY OR INDIRECTLY IN ANY MANNER DETRIMENTAL TO THE INTERESTS OF GAMMA INSTRUMENTS.

**GAMMA INSTRUMENT SERVICES**  
 90 Clairton Blvd.  
 Pittsburgh Pa. 15236  
 PHONE 412 633-9511/FAX 412 291-1245  
<http://www.hhinstrumentsag.com>

**Interconnect**  
 HK-7E/L3 RETRO-FIT  
 BK7EL3INT

DATE: 1/28/04  
 SCALE: N/A  
 CHECKED: N/A  
 SHEET 1 of 1