

**Basic Operating Principles of the HK-1 and 2 Microwave Instrument Systems
when used in water based liquids**

Each of the Microwave Instrument Systems that are manufactured by HK use microwave signals to determine the %Concentration or the %Total Solids of a liquid. The liquid being measured will contain a solid material, which is either suspended or dissolved in water.

Microwaves are electromagnetic waves similar to radio waves. Just like radio waves, microwaves are capable of traveling from a transmitter to a receiver in either a vacuum or through a space filled with a material. When a microwave signal travels in a vacuum; its speed, frequency, and energy are constant. When the space is filled with a liquid, the speed, frequency and energy of the wave is altered. By measuring the changes in the properties of the microwave signal, (particularly the Phase Shift of the wave), it is possible to determine the %Concentration or %TS of the liquid.

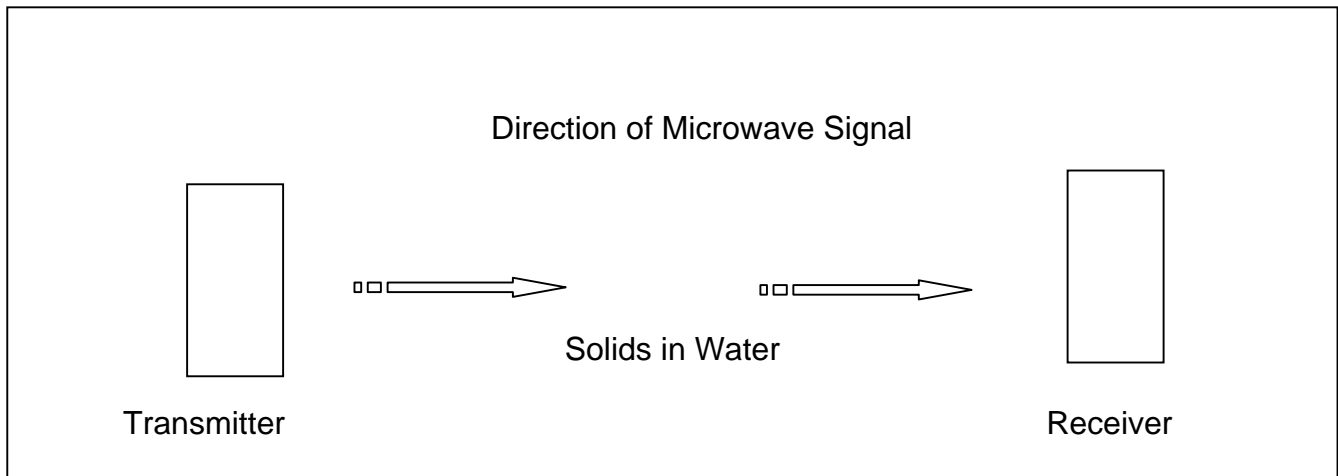

Figure 1

In most instances, the water molecules found in the liquid have the greatest effect on the microwave signal. They have a high dielectric constant.

The Dielectric Constant (k) is a number relating the ability of a material to carry alternating current to the ability of a vacuum to carry alternating current. Water has a k of about 80 and Most Solids of interest have k's of around 2.

HK INSTRUMENTS
PITTSBURGH, PA
412 653 7717

As the microwave signal travels from the transmitter to the receiver through the liquid, the water molecules absorb much of the microwave signal. The more water molecules per unit volume, the more the measured signal is altered. The more the signal is altered the higher the water content. The Higher the water content the lower the %Concentration or %Total Solids.

Actually, the Microwave Instrument is measuring the Total Dielectric of the Liquid. The more Solids there are in the liquid, the lower the Dielectric of the material.

There are other materials that can have a significant effect on the Total Dielectric. High percentages of salt will cause a liquid to have a high Dielectric because of the ions which are in the liquid. Typical amounts of salt (0-4%) are not a problem.

The HK-1 and 2 Measure Total Solids. This includes the dissolved and suspended solids. Refractometers measure only dissolved solids.

We measure both the attenuation and phase shift of the wave. The Phase Shift is an indication of the speed of the wave while the Attenuation is an indication of the energy lost while transmitting the material. Attenuation is not a good measurement of the Dielectric. Many process parameters affect the attenuation, making it a fickle measurement.

**We use the Phase shift to calculate the %Total Solids
by use of a linear transfer function:**

$$\%Total\ Solids = (Phase\ Shift\ in\ Degrees) \times (slope) + offset$$

HK INSTRUMENTS
PITTSBURGH, PA
412 653 7717

Technical data control unit (HK 1 and 2 Instrument Series)

System:	1 Microprocessor with EPROM memory
Housing:	IP 65, NEMA 4
Dimension (HK1)	HxBxD = 8.875" x 7.75" x 4.25"
Weight:	6.5 lbs.
Voltage:	230 / 115 V \pm 15%, 47-65 Hz
Power consumption:	230 / 115 V 50 VA
Signal output 1 (HK1 and HK2):	0/4 - 20mA; Isolated; Powered Current Loop; Max. Load Resistance 500 Ohms.
Signal Output 2 (HK1 only):	0/4 - 20mA; Non Isolated; Powered Current Loop; Max. Load Resistance 500 Ohms.
Signal Input 1 (HK1):	PT100 Temperature (2-wire connection and max. cable length 50 m.)
Signal Input 2 (HK1):	Current Input; Pressure, Load, and Conductivity
Signal Input 1 (HK2):	NTC Temperature Factory Supplied
HF-connection:	N-connection for microwave probe; max. cable length 2 meters with N- connectors.
RS 232 port:	4800, 9600 Bd
Display:	2 x 24 characters LCD, dialogue with push buttons and alphanumeric display.
Microwave frequency:	ISM - Band; Multi or 2.45 Ghz
Maximum power:	0dBm, 1mW
Sensitivity:	-80 dBm, 10 nW
Instrument outputs:	4 x PG11, 2 x Hf outputs with N-connectors at the bottom of the system.
Operating temperature:	0 °C to 50 °C
Storage temperature:	-40 °C to 85 °C
Standard BZT	ZZF no. requested
CE-mark	
Noise immunity:;	IEC 801, part 1-5
Radiation:	VDE 0871 Klasse B
Instrument safety:	IEC 1010-1

Principles of Signal Generation

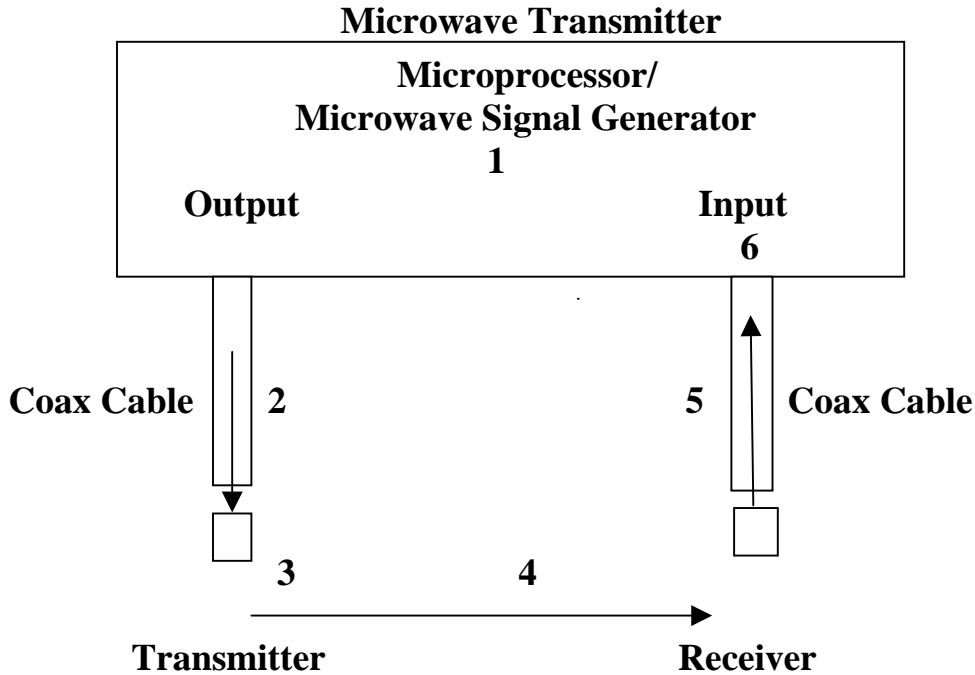

Figure 2

A) The HK Microwave System performs the following steps during its measurement cycle:

- 1) A microwave signal is produced in the Microwave Transmitter
- 2) The signal is transmitted from the Microwave Transmitter to an Insertion Sensor over a coax cable.
- 3) One Insertion Sensor acts as a transmitting antenna, and one acts as a receiving antenna.
- 4) The microwave signal transmits through the LIQUID from the transmitting antenna to the receiving antenna
- 5) From the receiving antenna the signal is transmitted back to the Microwave Transmitter
- 6) The Microwave Transmitter receives the signal and measures its properties