

**INDUSTRY:** KAOLIN CLAY PRODUCTION

**PRODUCT:** KAOLIN CLAY IN WATER

**APPLICATION:**

1. Measure the Concentration of a Waste Stream of Kaolin and Water as it is fed into a Settling Pond.
2. In the Settling Pond, Polymers are added to the water so that the Kaolin will sink to the bottom.
3. The Customer wants to control the amount of Polymers he adds to the Pond to a minimum.

This is a Continuous Process with our system being used for Closed Loop Control and Visual Monitoring.

**DESCRIPTION:** Major Problem -

1. The liquid mixture, which, arrives at the Settling Pond, contains air bubbles.
2. The Microwave System does not work well when there are air bubbles in the liquid.
3. A solution was needed which would overcome the problem of Air Bubbles in The Liquid.
4. This Solution is shown on Page 2.

**BENEFITS:**

**COST SAVINGS**

- By knowing the Concentration of the Kaolin Clay in the Waste Stream, the Customer will know exactly how much Polymer to add to the Pond.
- By only adding the amount of Polymers, which are required to sink the Kaolin Clay, the Customer saves money.
- The Customer will have more control and better understanding of the process.

**REPEATABILITY:** +/- 0.3 % is possible with a very good Calibration Curve.

**MEASURING RANGE:** .5% to 5% Concentration in the Kaolin Slurry is Typical.

**HK EQUIPMENT:** HK2-M IN LINE WITH A TWO INCH TEFLON LINED SPOOL PIECE

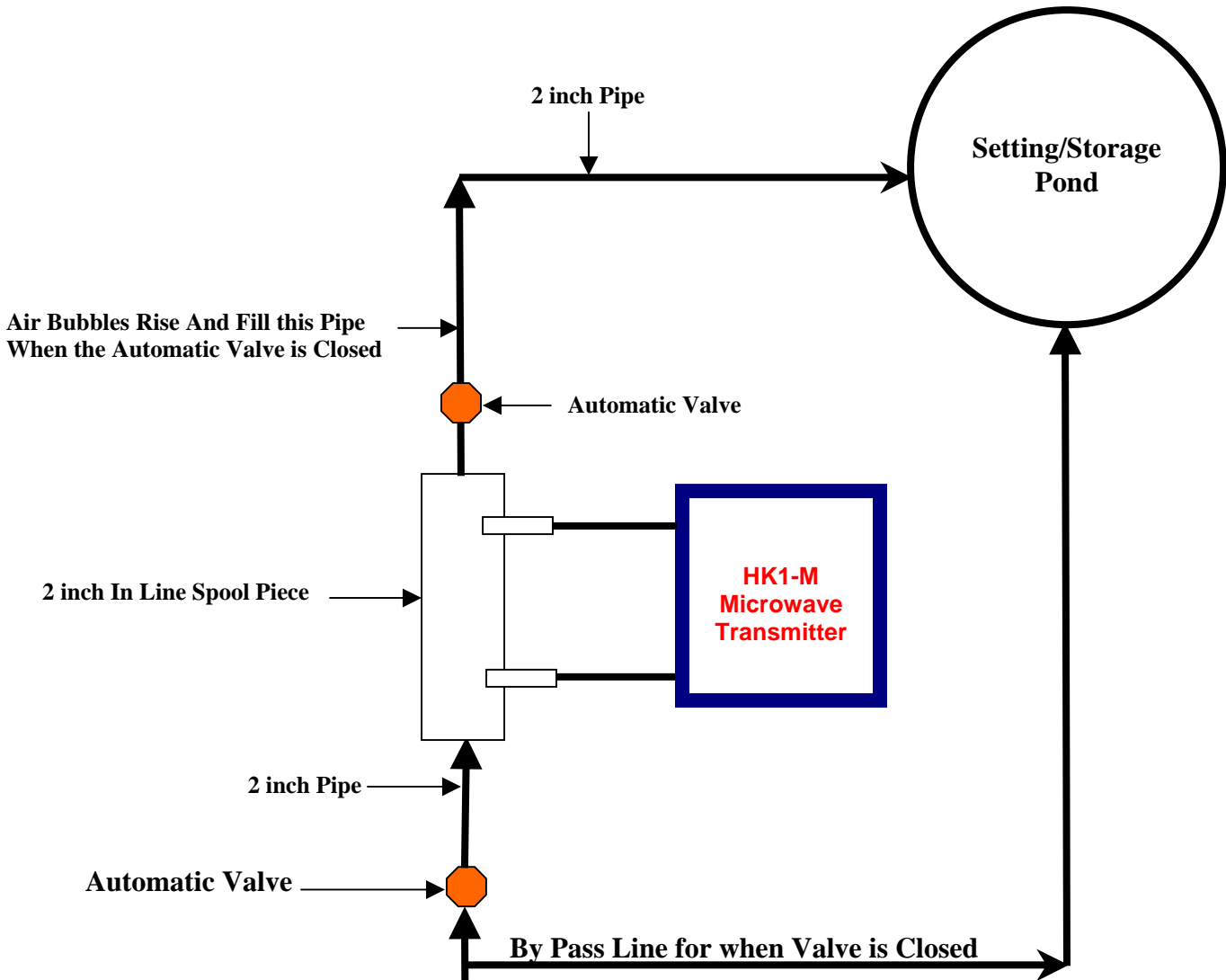

#### HOW THE MEASUREMENT IS MADE

1. The Liquid Mixture Flows for 30 seconds with the Automatic Valves Open.
2. The Automatic Valves then Shut. The In Spool Piece is full of Liquid and Air.
3. The Flow goes around the Spool Piece and directly into the Settling Pond when Valves are Shut.
4. With no flow in Spool Piece, the Air Bubbles Rise to the top of the Pipe above the Spool Piece.
5. The Microwave System makes a 10 second measurement of the Concentration with no Air in Liquid.
6. Valves are opened after measurement is made.
7. Repeat steps 1-6.

Kaolin in Water  
with Air Bubbles